

Novel Column Heater for Fast Capillary Gas Chromatography

E.U. Ehrmann*, H.P. Dharmasena, K. Carney, and E.B. Overton

Louisiana State University, Institute for Environmental Studies, 42 Atkinson Hall, Baton Rouge, LA 70803

Abstract

In this paper, we present two designs for the implementation of extremely fast temperature programming of gas chromatographic columns. Both designs incorporate heating and temperature-sensing elements placed along the column. Resistive heating controls the column temperature via a feedback circuit and a software-selected temperature program. Linear temperature increases up to 10°C/s are obtained. The performance of each design is evaluated for applications to volatile and semi-volatile hydrocarbons. Retention times deviate only slightly in comparison with a standard commercial instrument, and peak widths increase for compounds beyond C₁₃. The proposed column heater designs have satisfactory retention time reproducibility. They are lightweight and consume little power, making them promising alternatives for fast portable gas chromatography.

Introduction

The use of portable instrumentation for on-site analysis is a recent trend in analytical chemistry, especially for environmental applications. On-site analysis has certain advantages over laboratory analysis such as faster response times, less sample degradation, and fewer errors due to handling, transport, and storage of the sample. However, portable analytical instruments have their own requirements and limitations. They should be lightweight, consume little power, and have very short turnaround times in order to fully exploit the advantages of portability. At the same time, they should have appropriate accuracy and precision.

A wide variety of analytical instruments have been adapted for on-site work: open path Fourier transform infrared (FTIR), direct mass spectrometry (MS), gas chromatography (GC), and various selective sensors based on electrochemical reactions, mass loading, etc. GC presents the advantage of flexibility over selective sensors by allowing qualitative and quantitative analyses of complex mixtures rather than the determination of single target compounds. Also, in GC the analytes separate in the

column prior to their detection; this reduces potential interferences that cause particular problems in direct MS and FTIR.

Short, narrow bore capillary columns exhibit high resolution at elevated carrier gas velocities due to their small resistance to mass transfer contribution (1–3). This allows for very fast GC analyses in a technique known as fast or high speed GC. Portable gas chromatographs with these types of columns, though commercially available, are limited to isothermal operation. This severely restricts the scope of the instrument because only samples within a relatively narrow boiling point range may be analyzed in a reasonable amount of time. Temperature programming extends the potential of GC by expanding the accessible volatility ranges.

The elevated efficiency of the narrow bore capillary columns, together with the high carrier gas velocities in fast GC, permits very fast temperature programming rates without sacrificing significant resolution. The fast temperature programming rates translate into shorter analysis times, which is an important factor in portable instrumentation.

Almost all commercially available laboratory gas chromatographs and some portable instruments include the capability of accurate oven temperature programming. However, the ovens are bulky, require large amounts of electrical power, and their temperature programming capability typically has an upper limit of about 40°C/min. An alternative to large ovens, direct resistive heating of the column itself requires a minimum amount of power because only the column is heated. The idea of direct resistive heating was proposed several years ago (4), but only proven experimentally more recently. Yost and coworkers (5) heated commercial aluminum-clad columns by passing electrical current through the coating of the column. This approach, although theoretically very appealing, has practical limitations. For example, experiments that were performed in our laboratory showed that the differences between the thermal expansion coefficients of the fused silica and the aluminum caused the rupture of the coating and consequent damage of the column itself after a few thermal cycles.

Using the same concept, Phillips and coworkers (6,7) coated capillary columns externally with a conductive paint for resistive heating. Electrical current through the coating was

* Author to whom correspondence should be addressed.

programmed as a function of time so that the retention times of *n*-paraffins would show a linear dependence on their Kovat's indices. The appropriate electrical current profile was indirectly determined by iterative experiments until the desired normal paraffin separation was achieved. This process is rather time consuming, and the flexibility in temperature increases is limited. Moreover, the actual column temperature and heating rate are unknown. Mechanical instability of the conductive film that arises from differences in thermal expansion coefficients, as with the clad columns, could result in problems such as uneven heating and physical damage to the column.

In this work, we implemented the concept of resistive at-column heating using either a separate metal tube or a metal wire as a heating element. A microprocessor-controlled feedback circuit directly controlled the column temperature. For this, an additional temperature-sensing element, collinear with the column and the heater, was used to monitor the column temperature. The electronic board was used to compare the signal from the temperature sensor with the expected value according to the software-selected temperature program. A pulse width modulator on the electronic control board continuously adjusted the power that was applied to the column heater to maintain the desired temperature.

The applicability of the two different at-column heating devices for fast controlled temperature programming of narrow bore capillary columns was evaluated. The scope and limitations of the electronic control were established and compared with a standard commercial GC oven. The overall GC performance for *n*-paraffins C₁₀ to C₂₀ was likewise compared with a commercial GC oven in terms of accuracy, precision, and efficiency. Finally, the effect of additional external sheath gas flowing along the column and the heater was explored.

Experimental

Column assembly

All experiments were performed with 100- μm -i.d. thin wall WCOT capillary columns coated with a 0.4- μm film of methyl

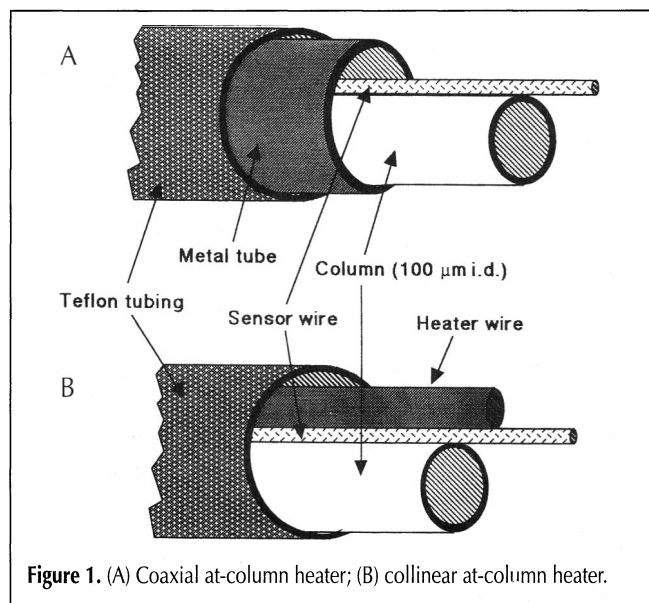

Figure 1. (A) Coaxial at-column heater; (B) collinear at-column heater.

phenyl (5%) silicone stationary phase (Quadrex, New Haven, CT). Two different types of heating systems were assembled. One of them, the coaxial heater, had 0.014-in. i.d. (0.022-in. o.d.) stainless steel tubing (Small Parts, Miami, FL) as the heating element. The stainless steel tubing was electroplated with a thin silver film to reduce the electrical resistance (AAA Polishing and Plating, Baton Rouge, LA). The thickness of the silver film was neither monitored nor determined; instead, the electrodeposition process was allowed to proceed until the total resistance of the tubing reached a value of approximately 3.5 ohm.

The coaxial heater comprises a 3.8-m-long piece of capillary column inserted along with the same length of an electrically insulated 0.002-in.-diameter nickel alloy 120 sensor wire (California Fine Wire) into a 3-m-long piece of silver-plated stainless steel tubing. For electrical insulation between column coils, the whole assembly itself was inserted into a 0.032-in. i.d. thin wall piece of Teflon tubing (Cole Parmer, Niles, IL). The insulating Teflon tubing was shorter than the stainless steel tube, allowing about 1/2 cm of exposed metal tube at each end. The ends of both the metal tube and the sensor wire were soldered to copper wires and connected to the electronic control board.

The second type of heating system, the collinear heater, was built using a 0.020-in.-diameter nickel alloy 90 wire (California Fine Wire) as the heating element instead of the stainless steel tubing. In this system, the column, sensor wire, and heater wire were inserted together into a 0.032-in. i.d. thin wall Teflon tube (Cole Parmer). As with the coaxial heater, copper leads were soldered to each end of both the heater and the sensor wire for connection to the electronic control board. Figure 1 contains schematic diagrams for both types of column heater assemblies.

The column assemblies were coiled around a 1-in.-diameter, 1.5-in.-long cylinder machined from silica alumina plates (Zircar, Florida, NY). This arrangement was either thermally insulated with glass wool or placed inside a rigid thermal insulator box machined from the same silica-alumina plates (Zircar).

Electronic control

The electronic control for the resistive column heating is an integral part of a control board that was built in-house for a pro-

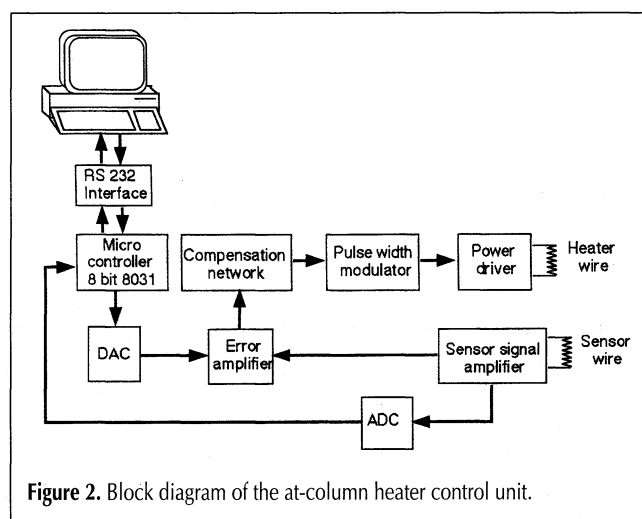

Figure 2. Block diagram of the at-column heater control unit.

totype portable gas chromatograph (8). Figure 2 shows a block diagram of the column heater control unit. The controller used an 8-bit Intel 87C51GB microcontroller (Intel, Santa Clara, CA) that included 256 bytes of RAM, two programmable counter arrays, an 8-channel, 8-bit A/D converter, and three 16-bit timer/counters. The firmware for the control board was written in 8031 assembly language and resided on a 128K EPROM. The controller board worked with DC input voltages that ranged from 10 to 30 VDC. In this work, two 12-V deep cycle batteries (34 Ah) were connected in series for the column heating.

The control board communicated with an external computer via an RS232 serial port. A Toshiba T3200 computer with Procomm V2.3 (PIL Software Systems, Columbia, MO) served as a dumb terminal for setting operational parameters. The sensor wire resistance, initial and final temperatures, delay times, and heating rate were downloaded to the controller via the serial link.

The controller maintained the column temperature using a pulse width modulator as follows. A small constant current (I) passes through the sensor wire. The resulting voltage drop (V) along the wire is proportional to the resistance (R) of the wire in the equation:

$$V = I \times R \quad \text{Eq 1}$$

The resistance R_T of the sensor wire at temperature T ($^{\circ}\text{C}$) is given by:

$$R_T = R_0 \times (1 + \alpha T) \quad \text{Eq 2}$$

where R_0 is the resistance at 0°C and α is the temperature resistance coefficient that is characteristic for a given metal. Combining Equations 1 and 2, we see that the voltage drop is proportional to the temperature of the sensor wire:

$$V_T = I \times R_0 \times (1 + \alpha T) \quad \text{Eq 3}$$

Every 10 ms, the controller computed the expected voltage according to the desired temperature-time profile and compared it with the measured voltage. The difference between the expected value and the actual value of the voltage constituted an error signal. A compensation network modified the phase and amplitude of the error signal to achieve proper temperature control and closed-loop stability. The output of the compensation network controlled a pulse width modulator that, in turn, drove a power MOSFET that was connected to the

heating element. The width of the pulses was proportional to the amplitude of the compensation network output and determined the heating rate.

To evaluate the performance, repeatability, and accuracy of the temperature control, the voltage-versus-time traces of the sensor wire were monitored and collected using a Nicolet 3091 digital storage oscilloscope (Nicolet, Madison, WI).

Chromatographic performance

An HP 5890 gas chromatograph with a split-splitless capillary injection port and an FID (Hewlett-Packard, Wilmington, DE) was used for all experiments. Data were acquired and processed with a Pascal Chem Station (Hewlett-Packard). The principal test mixture was a normal paraffin blend ranging from C_5 to C_{44} (Separation Systems, Gulf Breeze, FL). Headspace samples of the test mixture were manually injected using the split mode with a split ratio of 700:1. The carrier gas was helium at a column head pressure of 18 psig. Injector and detector temperatures were kept at 300°C and 320°C , respectively. Three sets of experiments were performed: (a) preliminary qualitative evaluation of both heater designs, (b) comparison of the collinear at-column heater performance with standard GC, and (c) evaluation of the effect of an external sheath gas flow along the column.

For the initial qualitative evaluation of the chromatographic performance, the coaxial and collinear at-column heating assemblies were placed individually inside the HP 5890 oven. The column ends were connected to the injector and the detector. The HP 5890 oven temperature control was disabled, which left the column temperature control solely to the at-column heating system. Normal paraffin and light crude oil chromatograms for both heating systems were obtained. The temperature was programmed from 50°C to 280°C at different linear rates ranging from 0.5°C/s to 5°C/s .

Following the preliminary evaluation, a more rigorous and quantitative comparison of only the collinear at-column heater with the HP 5890 oven was performed. A 3-m-long column was first installed as received in the GC oven, and five replicated chromatograms for n -paraffin headspace samples were obtained; the oven was heated from 50°C to 250°C at a temperature programming rate of 0.5°C/s (the upper limit of the HP 5890 oven). Subsequently, the same column was assembled into a collinear at-column heater system as described above, coiled, and placed into a silica-alumina insulating box. The whole column and heater assembly was set on top of the

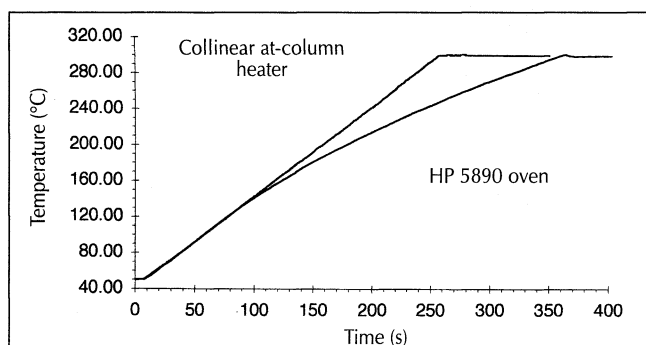

Figure 3. Comparison of the temperature profiles obtained with the HP 5890 and the direct at-column heater, 50°C – 300°C at 1°C/s .

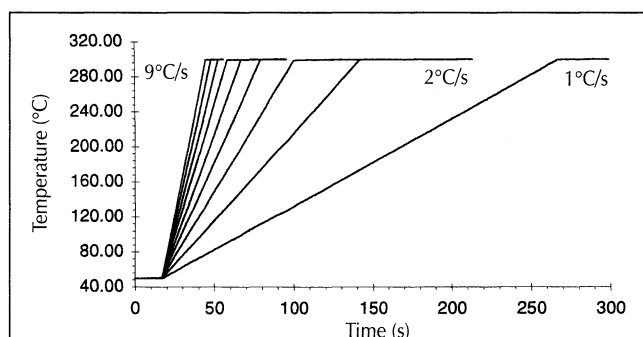

Figure 4. Temperature profiles obtained with the direct at-column heater, 1°C/s – 9°C/s .

HP 5890. The two ends of the column were introduced into the HP 5890 oven through a single hole in the top insulation and connected to the injector and detector. The column ends that extended out of the insulating box were expected to undergo larger heat losses than the main body of the column as a result of poorer thermal insulation. As a consequence, the temperature at the ends would be below the temperature of the main body of the column, which would create "cold zones." To eliminate the effect of the cold zones, the temperature of the column portion on top of the GC was controlled by the resistive heating, while the ends inside the oven were heated simultaneously at the same rate by the HP 5890 oven heater. In this way, the whole column should be heated uniformly. Five replicate chromatograms of the *n*-paraffin test mixture headspace were obtained at a temperature programming rate of 0.5°C/s.

Retention times and peak widths of the *n*-paraffins from C₆ to C₂₀ were determined for all chromatograms. The results were statistically compared using analysis of variance in a completely randomized design. Carbon number and type of heater were tested as the factors affecting retention times and peak widths. The response variables, retention times (*RT*), and peak widths (*PW*) were analyzed individually in a univariate approach. The effects of time or sequence in which the experiments were performed were considered negligible, based on the well-known stability of gas chromatographs and columns over time. The statistical analysis was performed with SAS software, version 6.08 (The SAS Institute, Cary, NC).

Additional experiments were performed to evaluate the effect of an external flow of sheath gas along the column, through the outer annular space in the Teflon tube. Retention times and peak widths that were obtained with and without sheath gas were statistically compared using univariate analysis of variance. The chromatograms without sheath gas were obtained with the collinear at-column heater evaluation setup described above. For the sheath gas supply, a piece of deactivated fused silica tubing (15 cm × 0.32 mm) (Restek, Bellefonte, PA) was inserted up to 3 cm into the detector end of the Teflon tubing. The opening of the Teflon tubing was sealed with high-temperature silicone sealant (Permatex; Loctite, Cleveland, OH). The other end of the fused silica tubing was connected to the packed column injection port of the HP 5890, which delivered a helium flow of approximately 5 mL/min to the Teflon tube.

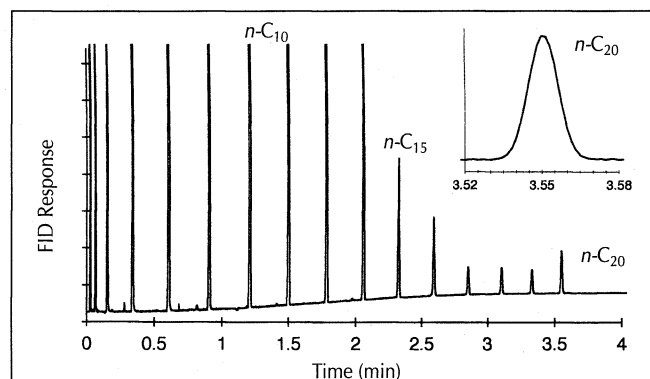

Figure 5. Chromatogram of *n*-paraffins C₆–C₂₀; 3 m × 0.1 mm phenyl (5%) methyl silicone; collinear at-column heater control from 50°C to 270°C at 1°C/s.

Results and Discussion

Preliminary Evaluation

Figure 3 shows the temperature profiles that were obtained with the HP 5890 oven heater and with the new collinear at-column heater at heating rates of 1°C/s. These profiles demonstrate the dramatic improvement in ramp accuracy and linearity achieved by using the direct at-column heating system. Temperature increases from 0.5°C/s to 10°C/s exhibit a very good linearity and negligible overshoot at the final temperature (Figure 4). Power consumption for the heating system increased with the temperature programming rate and with column temperature. During the extreme conditions of 10°C/s heating from 50°C to 280°C, the system used a maximum power of 60 watts. This value, comparable to that of a household light bulb, is compatible with battery operation. Cool down times varied considerably with the type of insulation. For a well-insulated column, cool down times from 280°C to 50°C were up to 5 min. The addition of a small fan on one side of the insulating box and a small opening on the opposite side reduced the cool down time to 1 min, without substantially affecting the power consumption during the heating cycle.

The chromatograms that were obtained for *n*-paraffins C₅–C₂₀ (exemplified in Figure 5) at different temperature programming rates show good separation in short analysis times and symmetric peak shapes. Figure 6 shows a considerable separation of a light crude oil sample in 5 min at a temperature programming rate of 1°C/s. This constitutes a more than sixfold reduction in analysis time compared to current GC methods used for oil fingerprinting (9).

The collinear at-column heater and the coaxial at-column heater performed similarly, despite the expected advantage of radial heating with the coaxial heater. However, the coaxial heater had some practical limitations. As with other "coated" heating elements, differences in the thermal expansion coefficients between the support and the coating caused mechanical stability problems. The silver film tended to peel off the stainless steel tubing, which caused heterogeneity in the tubing resistance. The resulting uneven tubing resistance ultimately caused hot spots that burned the insulation of the sensor wire and caused a short circuit in the temperature controller. Additionally, the system proved to be mechanically fragile at the points where the column exits the tube. Abrasion between the

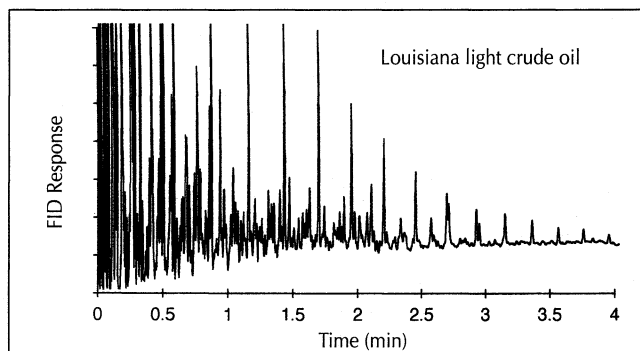

Figure 6. Chromatogram of Louisiana light crude oil; 3 m × 0.1 mm phenyl (5%) methyl silicone; collinear at-column heater control from 50°C to 270°C at 1°C/s.

tube rim and the exiting capillary column, aggravated by differences in the thermal expansion coefficients of the metal tube and the fused silica, damaged the polyimide coating and the column itself. In summary, the simultaneous constraints of dimension, resistance, thermal expansion coefficient, and price imposed substantial practical problems in the use of the coaxial at-column heater.

Comparative evaluation

The promising initial performance of the collinear at-column heater warranted a more rigorous comparison with existing standard column heating technology. Thus, chromatographic compliance of the collinear at-column heating system was compared with the oven of the HP 5890 GC at the highest reliable temperature programming rate of the latter. The injector, detector, column, and operating parameters that were used were exactly the same for both heaters; thus, any observed differences should have arisen from the heating process only.

Some common methods for the evaluation of column efficiency under isothermal conditions are the determination of the number of theoretical plates (N) and the related height equivalent to a theoretical plate (H). For temperature-programmed operation, the values of the resolution (R) or the separation number (TZ) are more useful. Every one of these parameters is determined from the retention time and the peak width of one or more analytes. However, the column temperature conditions affect the retention time and peak width differently (10). The aim of this work was to compare the performance achieved with the conventional GC oven versus the collinear at-column heating device. Because we used the same column throughout the study, we could compare the retention times and peak widths independently, rather than analyze the resolution or separation number.

Figure 7 shows the retention times that were obtained with the conventional oven and the collinear at-column heater. Results from the analysis of variance confirmed that the differences in retention times that were observed between the two heating systems were statistically significant, regardless of the analyte considered. Also, the interaction between the heating device and the carbon number of the analyte was statistically significant. In other words, the differences between the retention times that were obtained for the collinear at-column heater and the GC oven varied with the analyte. For n -paraffins

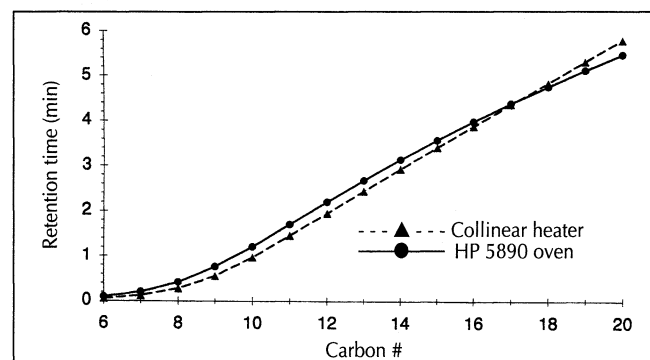

Figure 7. Comparison of n -paraffin C_6 – C_{20} retention times obtained with a standard GC and the collinear at-column heater; 3 m \times 0.1 mm phenyl (5%) methyl silicone; temperature program from 50°C to 270°C at 0.5°C/s.

up to C_{16} , the retention times for the collinear at-column heater were smaller than those for the conventional GC oven, which suggested that the actual temperature of the directly heated column was above its nominal value (considering the GC oven the standard of comparison). For n -paraffins C_{17} and higher, retention times for the collinear at-column heater were larger than those for the conventional GC oven, implying that, at high temperatures, the resistively heated column either had an average temperature below the set point or had a significant cold zone next to the detector. The largest absolute difference in retention time was 19 s (5.7%), which was obtained for n - C_{20} .

Several factors could be responsible for the differences in retention times between the two heating systems. Overheating by the collinear at-column heater at low temperatures could result from errors in the measurement of the initial resistance of the sensor wire. Minor "cool" zones along the column (for instance, at the region where the column ends pass through the GC oven insulation) could have a negligible effect on the retention time of the smaller paraffins but retard the elution of the higher homologues. Studies of the influence of these factors, as well as more rigorous procedures for determining the temperature versus resistance relationship of the sensor wire, are underway.

An important parameter in GC is the stability or reproducibility of the retention times. Table I contains the standard deviations (SD) and relative standard deviations (RSD) of retention times for both heaters. The average retention time SD of the HP 5890 GC oven was 0.2 s (RSD < 0.3%), and the average value for the collinear at-column heater was twice as large (0.36 s, RSD < 1%). Despite the lower retention time precision of the at-column heater, its absolute reproducibility is still satisfactory. RSDs of less than 1% allow reliable identification of analytes by using a relative retention time strategy such as the Kovat's index system. The lower precision in retention times that is achieved with the resistive column heating device indicates a lower precision or repeatability in the actual temperature profile over time. Uncontrolled heating at small portions of the column, as happens in the regions where

Table I. Retention Time Repeatability for the Standard GC Oven and the Collinear At-Column Heater. Standard Deviations of Five Consecutive Runs.

Compound	HP 5890 oven		Collinear at-column heater	
	SD (s)	RSD (%)	SD (s)	RSD (%)
n - C_{10}	0.19	0.27	0.57	0.98
n - C_{11}	0.21	0.20	0.37	0.42
n - C_{12}	0.21	0.16	0.42	0.36
n - C_{13}	0.19	0.12	0.39	0.27
n - C_{14}	0.19	0.10	0.42	0.24
n - C_{15}	0.16	0.07	0.28	0.14
n - C_{16}	0.15	0.06	0.36	0.15
n - C_{17}	0.14	0.05	0.27	0.10
n - C_{18}	0.12	0.04	0.50	0.17
n - C_{19}	0.06	0.01	0.45	0.14
n - C_{20}	0.14	0.04	0.52	0.15

the column transverses the GC oven top, could cause the reduction in overall temperature precision. Reduction of uncontrolled temperature zones are underway in a revised design of the at-column heater and the experimental setup.

Previous experiments showed that the effect of injection quality on peak width and shape was significant for compounds below C_{10} . Because this study concerned the column heater and not the injector, only paraffins C_{10} and higher were considered in the peak width analysis. The comparison of the peak widths that were obtained with the new at-column and the standard oven heating system indicated a significant erosion of column efficiency in the at-column heating system. Figure 8 shows an exponential increase in the peak width with the carbon number of the test compounds when the column was resistively heated. In contrast, the peak widths of the C_{10} – C_{20} n -paraffins that eluted from the column heated with the standard oven were almost constant. It is evident from Figure 8 that the relative increase in peak width for the at-column heating versus the standard oven was a function of the retention time of the test compound, which is proportional to the vapor pressure of the compound in a non-polar column. The results from the standard oven indicate that no significant peak width increase was associated with increasing retention time or capacity factor under the temperature programming conditions used. Consequently, an additional phenomenon other than the slightly larger residence time of the heavier analytes in the directly heated column must be responsible for the large increase in the peak widths of those compounds. Also, the fact that the n -paraffins below C_{17} , which have smaller retention times in the directly heated column, exhibit larger peak widths in the same system indicates that the peak broadening is not proportional to the retention time differences.

Considering that the peak broadening is exponentially related to the carbon number of the analyte, a cold zone is likely to cause the deterioration in peak width. The uncontrolled section of the column that penetrates the oven top probably constitutes a relatively cold zone in which high boiling point compounds experience significant peak broadening.

Another probable cause for the peak width increase is nonuniformity along the column. According to Blomberg, "The net result of nonuniformity is erosion of efficiency and resolution" (11). He also stated that, "Significant losses are unlikely unless the medium becomes very lumpy" (11). A very lumpy medium

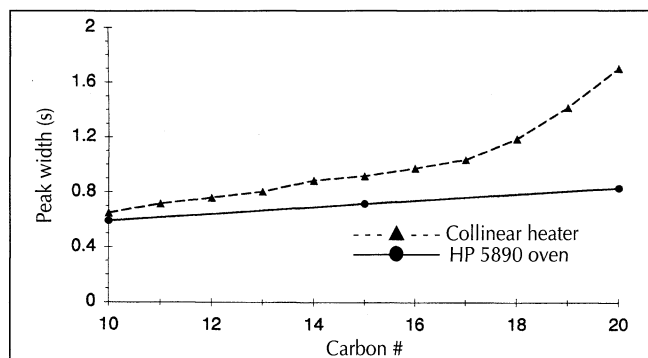

Figure 8. Comparison of n -paraffin C_{10} – C_{20} peak widths obtained with a standard GC and the collinear at-column heater; 3 m \times 0.1 mm phenyl (5%) methyl silicone; temperature program from 50°C to 270°C at 0.5°C/s.

in this case would be a column with highly significant temperature gradients. However, given the similarity in retention times observed between the two heating systems and the symmetry of the peaks eluted from the resistively heated column, extreme temperature gradients along the whole column seem unlikely. Consequently, the main factor responsible for the high increase in the peak width of the less volatile analytes should be the presence of a localized cold zone as discussed in the previous paragraph. Optimization of the experimental setup to minimize potential cold spots and a closer investigation of the causes for the observed peak broadening are underway.

Effect of sheath gas flow

Given the possibility that the at-column heating was not entirely uniform, the effect of a small flow of external sheath gas along the outside of the column and the heater wire was investigated. The sheath gas could have carried away excess heat from hot spots to cooler areas of the column, thus enhancing thermal homogeneity along the column. This smoothing of the temperature should translate into a reduction of the peak widths of the analytes and possibly changes in their retention times.

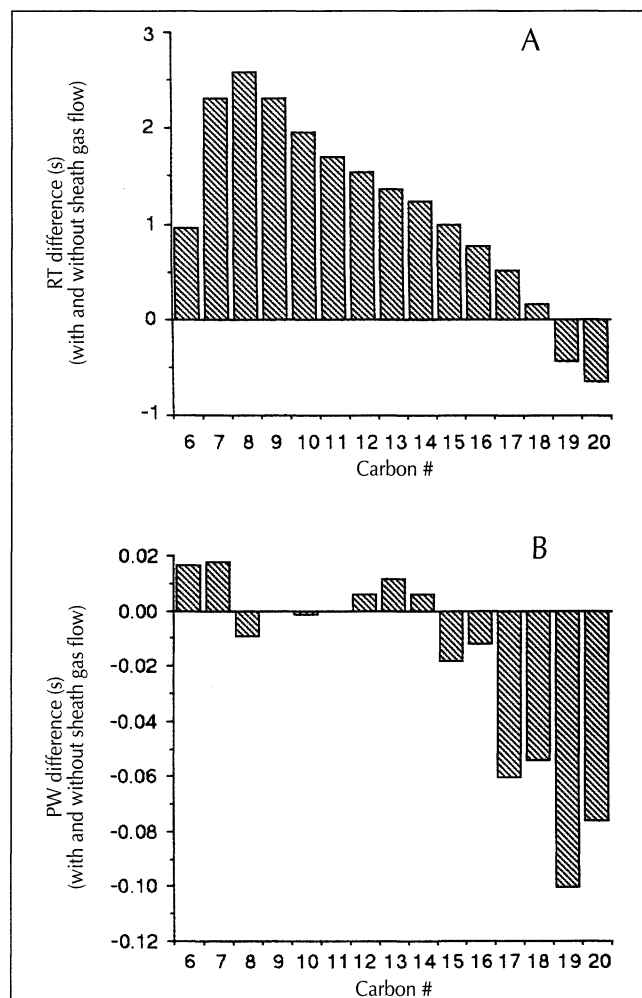

Figure 9. Effect of a sheath gas flow on the collinear at-column heater performance: (A) differences in retention times of n -paraffins with and without sheath gas flow, (B) differences in peak widths of n -paraffins with and without sheath gas flow. 3 m \times 0.1 mm phenyl (5%) methyl silicone; temperature program from 50°C to 270°C at 0.5°C/s.

The differences between retention times with and without sheath gas (Figure 9A) showed that the effect of the sheath gas depended on the volatility of the analytes. The sheath gas flow increased the retention times of the compounds below C_{18} and decreased the retention times of $n-C_{19}$ and $n-C_{20}$. The difference in retention time was largest for $n-C_8$ (SD, 2.58 s; RSD, 12%) and decreased almost linearly with the carbon number of the analyte. Thus, the performance of the at-column heated system with a sheath gas flow came slightly closer to the standard GC oven performance, perhaps because the "average" temperature registered by the sensor wire more accurately represented the temperature at all points in the column. As interesting as these results seem, a closer look at the relative magnitudes of the retention time shifts using a sheath gas flow (maximum, 2.58 s) compared to the maximum differences encountered between the two heating systems (19 s) clearly shows that the effect of sheath gas, although statistically significant, was rather negligible on the heater performance.

Figure 9B shows the effect of sheath gas on peak widths. The statistical comparisons of peak widths with and without sheath gas for each carbon number showed that the peak widths were significantly reduced only for compounds C_{17} and higher. However, as was the case for retention times, the relative effect of the sheath gas flow on the peak widths was rather small (maximum difference, 0.08 s; 4% reduction for $n-C_{20}$).

Overall, the results of the sheath gas evaluation show that even though there is a statistically significant beneficial effect of the sheath gas flow on chromatographic performance, its absolute magnitude is too small to justify the additional instrumental complexity. However, these results further support the hypothesis that small nonuniformities in the column temperature play only a minor role in the loss of efficiency.

Conclusion

In this study, two low-power consumption at-column resistive heating systems were described and evaluated. The systems were capable of directly controlling and accurately programming the column temperature from 50°C to 300°C, at temperature increases up to 10°C/s or more, via an electronic feedback circuit. The heating systems were tested for broad boiling point range samples and provided satisfactory resolution and symmetric peak shapes over the entire range. The size, power consumption, and cool down times of both systems were compatible with portable fast GC of volatile and semivolatile compounds.

The collinear at-column heating system provided a satisfactory retention time reproducibility with RSDs of less than 1%. Comparison with a standard GC oven demonstrated minor deviations in retention times, which probably resulted from uncontrolled temperature zones that were due to the experimental setup and not from the heater control itself. Significant increases in peak widths relative to a standard GC oven were observed, particularly for compounds C_{17} and higher. Zones with

uncontrolled temperature due to the experimental setup, as well as slight temperature gradients along the column, are possible explanations for these observations. In spite of the relative loss of chromatographic efficiency for the heavier compounds, the GC performance was still adequate, considering the low power consumption, weight, and size of the system. The experimental setup and details in the heater design are currently being optimized for higher efficiency.

The addition of an external flow of sheath gas along the column had a statistically significant beneficial effect upon retention times and peak widths of heavier compounds. However, the magnitude of the effect was too small to justify the additional instrumental complexity.

Acknowledgment

The content of this paper was presented on March 10, 1995 at Pittcon '95, held in New Orleans, LA.

References

1. R. Tijssen, N. van den Hoed, and M.E. van Kreveld. Theoretical aspects and practical potentials of rapid analysis in gas chromatography. *Anal. Chem.* **59** (7): 1007–15 (1987).
2. K.J. Hyver and R. Phillips. Considerations in enhancing resolution, speed, and sensitivity in capillary gas chromatography and gas chromatography-mass spectrometry. *J. Chromatogr.* **399**: 33–46 (1987).
3. G. Lee, C. Ray, R. Siemers, and R. Moore. Recent developments in high speed gas chromatography. *Am. Lab.* **21**: 110–119 (1989).
4. M.L. Lee, F.J. Yang, and K.D. Bartle. In *Open Tubular GC: Theory and Practice*. John Wiley and Sons, New York, NY, 1984, pp. 107–110.
5. M.E. Hail and R.A. Yost. Compact gas chromatograph probe for gas chromatography/mass spectrometry utilizing resistively heated aluminum-clad capillary columns. *Anal. Chem.* **61**: 2410–16 (1989).
6. V. Jain and J.B. Phillips. Fast temperature programming on fused-silica open tubular capillary columns by direct resistive heating. *J. Chromatogr. Sci.* **33**: 55–59 (1995).
7. J.B. Phillips and V. Jain. On-column temperature programming in gas chromatography using temperature gradients along the capillary column. *J. Chromatogr. Sci.* **33**: 541–50 (1995).
8. E.B. Overton and K.R. Carney, U.S. Patent Application 08/181, 705 (1994).
9. D.E. Roques, E.B. Overton, and C.B. Henry. Using GCMS fingerprinting analysis to track process and progress of oil degradation. *J. Environmental Quality*, **23**: 852–55 (1994).
10. E.J. Cavalli and C. Guinchard. Empirical approach to the dependence of plate height on temperature and gas velocity in gas chromatography. *J. Chromatogr. Sci.* **33**: 573–77 (1995).
11. L. Blomberg and T.A. Berger. Variance of a zone migrating in a non-uniform time-invariant linear medium. *J. Chromatogr.* **596**: 1–13 (1992).

Manuscript accepted July 8, 1996.